

M9108, M9116, M9124, and M9132 Series Electric Non-Spring Return Actuators

Installation

IMPORTANT: The M91xx Series actuators are intended to control equipment under normal operating conditions. Where failure or malfunction of an M91xx Series actuator could lead to an abnormal operating condition that could cause personal injury or damage to the equipment or other property, other devices (limit or safety controls) or systems (alarm or supervisory) intended to warn of, or protect against, failure or malfunction of the M91xx Series actuator must be incorporated into and maintained as part of the control system.

Mount M91xx Series actuators in any convenient orientation. Install the actuators on a 3/8 to 3/4 in. (9.5 to 19 mm) round shaft or a 3/8 to 5/8 in. (9.5 to 16 mm) square shaft, 2 in. (51 mm) or longer. If the shaft is less than 2 in. (51 mm) long, install an extension recommended by the damper or valve manufacturer. Use the M9000-154 1 in. Jackshaft Coupler Kit for 1 in. (25.4 mm) outside diameter shafts.

To mount the actuator, proceed as follows:

1. Press and hold the gear release lever, and rotate the coupler to the 0 or 90° position. Release the gear release lever. (See Figure 1.)

Parts Included

All Models

- M91xx Series actuator
- M9000-160 anti-rotation bracket
- two No. 12-24 x 1/2 in. self-tapping hex washer-head screws

M9124- and M9132-AGA Models

Includes one M9000-105 pluggable 3-terminal block.

M9124- and M9132-AGD and AGE Models

Includes two M9000-105 pluggable 3-terminal blocks.

M9124- and M9132-AGC Models

Includes three M9000-105 pluggable 3-terminal blocks.

Special Tools Needed

- torque wrench with 10 mm socket
- digital voltmeter or M9000-200 Commissioning Tool (for HGx models with zero and span potentiometers)

Mounting

IMPORTANT: The actuator is intended for indoor mounting only, with no direct exposure to water beyond NEMA 2 conditions. Use an appropriate shield or enclosure where the environment exceeds NEMA 2 specifications.

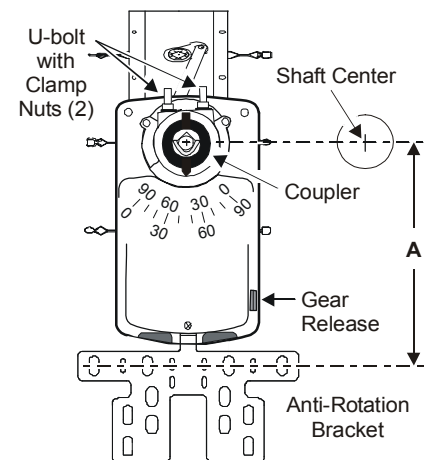

Note: A is the distance from the center of the holes in the anti-rotation bracket to the center of the shaft. (See Table 1.)

Figure 1: Mounting Positions

Table 1: Shaft Sizes and Distances from the Anti-Rotation Bracket to Shaft Center

Shaft Diameter	5/8 in.	1/2 in.	3/8 in.
A Dimensions	6-1/8 in.	6-3/16 in.	6-1/4 in.
(See Figure 1.)	(155 mm)	(157 mm)	(159 mm)

- Bend or cut the anti-rotation bracket to fit the damper frame or duct as shown in Figure 2.

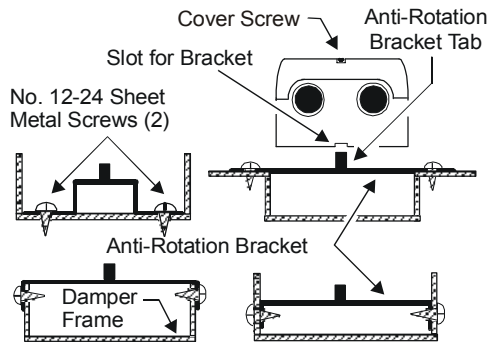

Figure 2: Anti-Rotation Bracket Positions

- Close the damper.
- Insert the anti-rotation bracket tab into the slot at the bottom of the actuator (shown in Figure 2), and slide the actuator onto the shaft.

IMPORTANT: The tab on the anti-rotation bracket must fit midpoint in the actuator slot to prevent actuator binding and premature wear.

- Use the anti-rotation bracket as a guide, and drill the holes in the damper frame or duct for the bracket (using dimension **A** shown in Figure 1 and the measurements in Table 1).

Note: When installing the actuator to a Johnson Controls damper, use the existing holes in the damper frame.

- Attach the anti-rotation bracket to the damper frame or duct with the two self-tapping screws provided, using a 1/4 in. (7 mm) flat-blade screwdriver or 5/16 in. (8 mm) nut driver.

IMPORTANT: Do not overtighten the mounting screws to avoid stripping the threads.

- Slide the actuator onto the damper shaft, positioning the tab on the anti-rotation bracket midway into the slot at the bottom of the actuator.

IMPORTANT: For Variable Air Volume applications that use an M9108 Series actuator, secure the coupler to the shaft with the damper in the fully open position to avoid damaging the open position end-stop.

- Hold the actuator in place, and evenly hand tighten each clamp nut onto the U-bolt. Secure the U-bolt to the damper shaft to achieve a torque of 100 to 125 lb-in (11 to 14 N·m).

- Press and hold the gear release. Rotate the coupler fully closed to fully open to verify that the damper and actuator rotate freely throughout the range.

Rotation Range

The actuator is factory set for 0 to 90° rotation. To change the rotation range to less than 90°, use the top scale on the actuator cover, refer to Figure 3, and proceed as follows:

- Press and hold the gear release, and rotate the actuator coupler Counterclockwise (CCW) to the 0° position. Release the gear release.

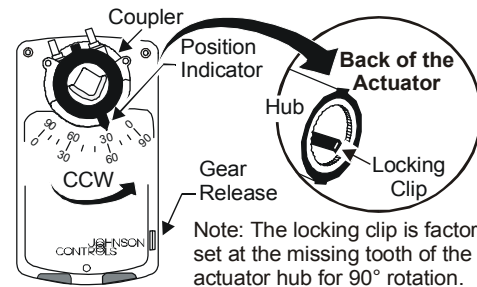

Figure 3: M91xx Actuator Components

- Turn the actuator over. Use a flat-blade screwdriver to release the locking clip, and remove the coupler from the front of the actuator.
- Reinsert the coupler into the front of the actuator, and align the position indicator with the starting point of the desired rotation range.

IMPORTANT: Advancing the coupler 90° from the factory setting prevents the actuator from driving in either the Clockwise (CW) or CCW direction.

- Push the coupler into the actuator until the locking clip snaps over the hub, securing it in place.

Note: To change the rotation range on:

- xGC models with auxiliary switches, one or both of the switches may need adjustment. See the *Auxiliary Switches (xGC Models)* section.
- HGx models with zero and span potentiometers, adjust both potentiometers. See the *Potentiometers (HGx Models)* section.

Feedback Signal

For **AGD and AGE models**, resistance feedback is reduced corresponding to the reduced rotation range.

For the **GGx, HGx, and JGx models**, changing the rotation range changes the feedback signal and the operating range proportionally. (See Figure 4.)

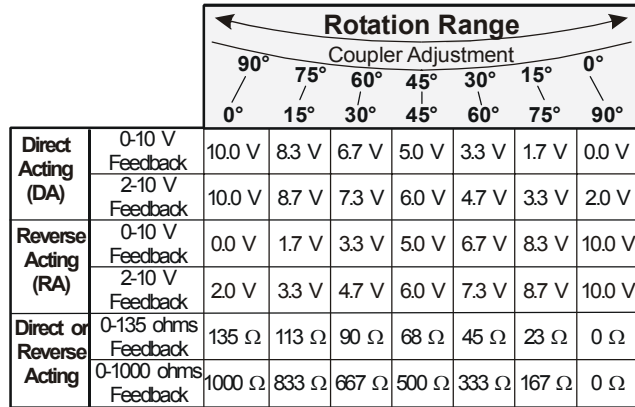

Note: 0 to 10 V or 2 to 10 V feedback is available on all GGx, HGx, and JGx models, 0 to 135 ohms feedback is available on AGD models, and 0 to 1000 ohms feedback is available on AGE models.

Figure 4: Nominal Feedback Signal Relative to the Rotation Range

Wiring

CAUTION: Risk of Equipment Damage.
 Disconnect all power supplies before making wiring connections or prior to performing maintenance. Check all wiring connections before applying power to the system. Short-circuited or improperly connected wires result in permanent damage to the equipment.

IMPORTANT: Make all wiring connections in accordance with local, national, or regional regulations.

Refer to Figure 5 for the applicable M91xx actuator.

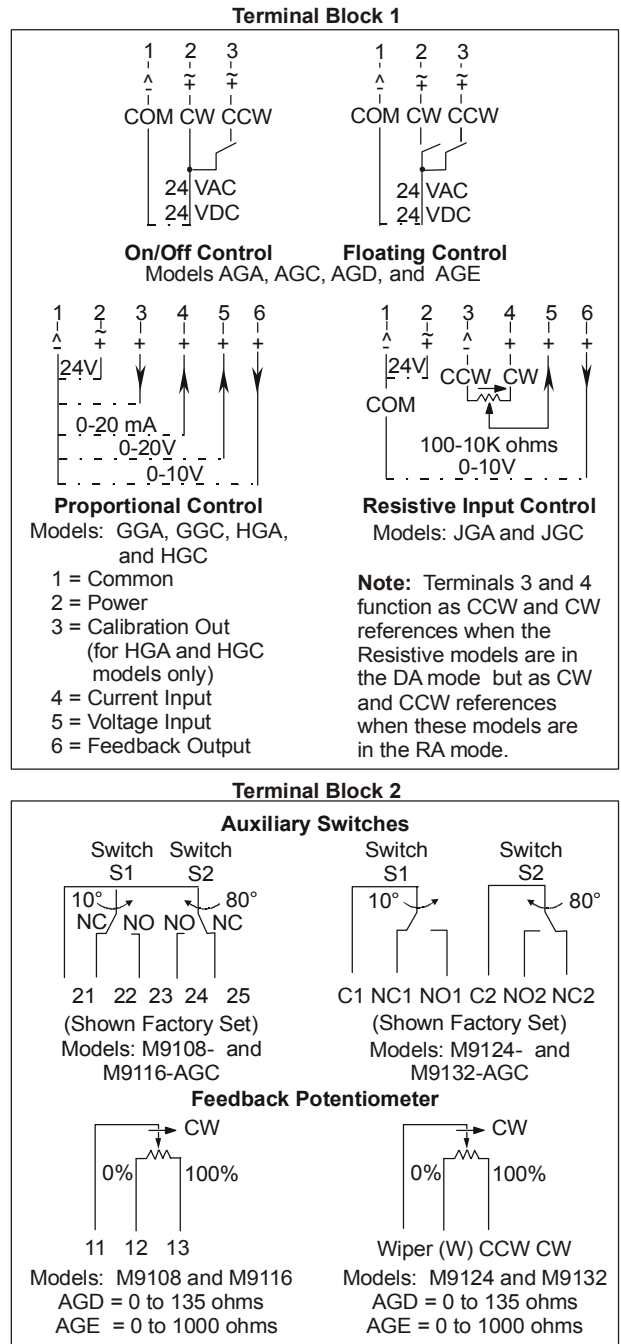

Figure 5: Wiring Diagrams for M91xx Models

Through the Conduit Openings

Depending on the M91xx Series model selected, use one or both conduit openings. The threaded actuator conduit openings accept 1/2 in. trade size conduit fittings. Refer to Figure 6 and proceed as follows:

1. Loosen the cover screw with a Phillips No. 1 screwdriver, and remove the actuator cover.

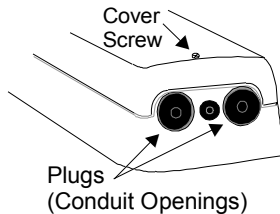

Figure 6: Location of the Conduit Openings

2. Push the plastic plug out of the conduit opening with fingertip.
3. Use the Phillips screwdriver to puncture a hole through the center of the plug, and reinsert the plug into the conduit opening.

Note: For applications requiring metal conduit, thread the conduit fitting into the conduit opening and hand tighten.

IMPORTANT: Use flexible metallic tubing or its equivalent with the fitting. Do not overtighten the conduit fitting into the actuator to avoid damaging the actuator threads.

4. Insert the cable wires through the plastic plug or conduit fitting, and connect to the terminal block using the applicable wiring diagrams in Figure 5.
5. Perform the procedures appropriate to the specific application, as described in the *Tandem Operation* and *Setup and Adjustments* sections.
6. Reattach the cover and tighten the cover screw.

Tandem Operation

The tandem configuration provides twice the torque of a single actuator as follows:

- 280 lb-in (32 N·m) for two M9116-GGx or M9116-HGx units
- 420 lb-in (48 N·m) for two M9124-GGx or M9124-HGx units
- 560 lb-in (64 N·m) for two M9132-GGx or M9132-HGx units

The actuators operate in exact synchronization, ensuring the load is split evenly between each unit.

Models with the same torque and control input may be mounted in tandem. For example:

- M9116: two GGx, two HGx, or one GGx and one HGx
- M9124: two AGx, two GGx, two HGx, or one GGx and one HGx
- M9132: two AGx or two GGx

Note: Do not use **M9108 Series** models in tandem.

The Master/Slave Jumper is factory set in the master position. Determine the method for mounting the two actuators in tandem: front-to-back (Figure 7 shows the front view) or back-to-back, and proceed as follows:

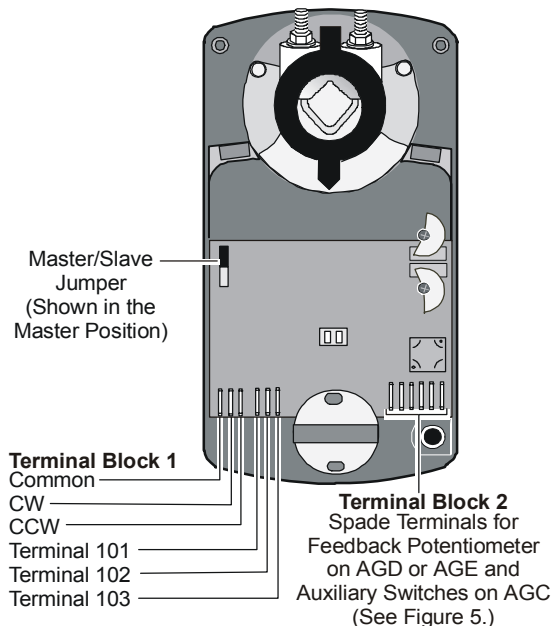

Figure 7: Settings on AGx Models

1. Designate one actuator as the master, and move Master/Slave Jumper on the other actuator to the slave position.
2. Connect Terminal 101, Terminal 102, and Terminal 103 from the master actuator to the corresponding terminals on the slave actuator. (Refer to Figure 7 for AGx models and Figure 8 for GGx and HGx models.)
 - a. When mounting two actuators front-to-back on the same shaft, connect:
 - Terminal 101 from the master actuator to Terminal 101 on the slave actuator.

- Terminal 102 from the master actuator to Terminal 102 on the slave actuator.
 - Terminal 103 from the master actuator to Terminal 103 on the slave actuator.
- b. When mounting two actuators back-to-back on the same shaft, connect:
- Terminal 101 from the master actuator to Terminal 102 on the slave actuator.
 - Terminal 102 from the master actuator to Terminal 101 on the slave actuator.
 - Terminal 103 from the master actuator to Terminal 103 on the slave actuator.

The total wire length for these connections may be up to 30 ft (9 m).

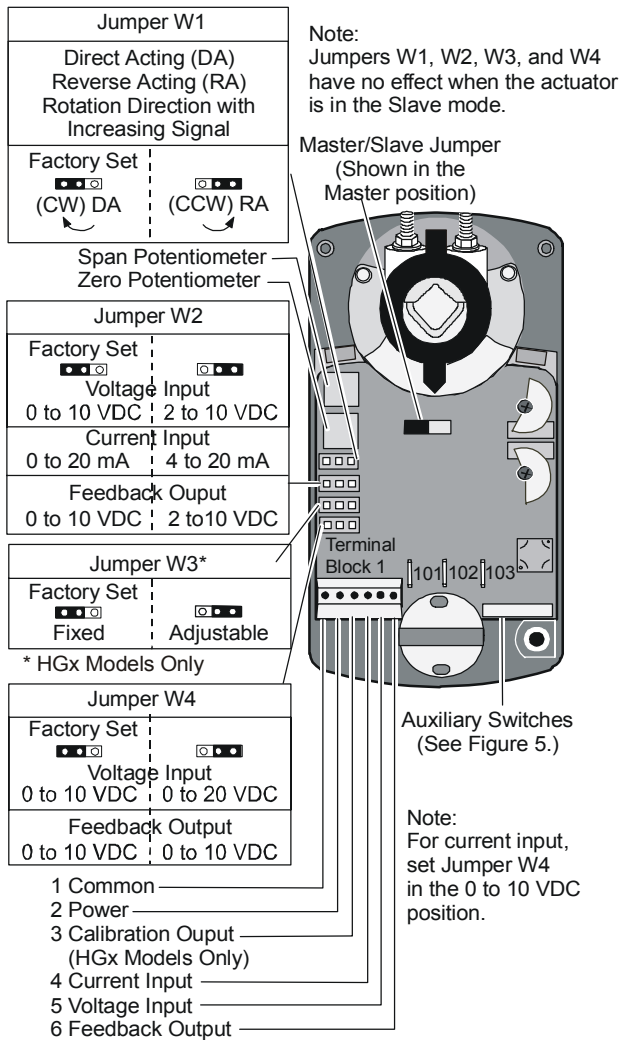

Figure 8: Settings on GGx and HGx Models

3. Connect the input control signal:
 - For **AGx models**, connect the input control signal to the common, CW, and CCW terminals on both the master and the slave actuators. (See Figure 7.)
 - For **GGx and HGx models**, connect the control signal to the master actuator, and connect 24 VAC/VDC power to both the master and slave actuators.

IMPORTANT: For proper tandem operation, do not connect the control input to the slave unit.

Note: Set the master actuator jumpers on the **GGx and HGx models** according to the action and signal range desired before proceeding. (Refer to Figure 8 and the *Setup and Adjustments, Calibration* section.)

4. Make sure of the following if the actuators configured for tandem operation stall or fail to drive:
 - a. Both actuators have the same torque and control input.
 - b. One actuator is set as the master and the other as the slave.
 - c. The control signal is connected to the master actuator only.
 - d. Terminal 101, Terminal 102, and Terminal 103 are connected properly, as described in Step 2.

Setup and Adjustments

Calibration

Calibrate only the actuator designated as the master when using **two AGx, GGx, or HGx models in tandem**.

Direction of Action

In the DA mode (factory set), a minimum control signal drives the actuator to the full CCW position, and a maximum control signal drives it fully CW. In the Reverse Acting (RA) mode, a minimum control signal drives the actuator to the full CW position, and a maximum control signal drives it fully CCW. To set an actuator for RA, proceed to the section for the appropriate model.

IMPORTANT: Adjust the rotation range before changing the direction of action.

AGx Models

To set one of these models for RA operation, reverse the control wiring connections at Terminal 2 and Terminal 3. (See Terminal Block 1 in Figure 5.)

GGx, HGx, and JGx Models

To set one of these models for RA operation, proceed as follows:

1. Press and hold the gear release, rotate the actuator coupler until it is in the full CW position, and release the gear release.
2. Move Jumper W1 from the factory-set DA position to the RA position. (See Figure 8.)
3. Apply power and then a control signal to the actuator to verify that the actuator is fully CW at minimum control input, and fully CCW at maximum control input.

Note: HGA and HGC models may require potentiometer settings. Proceed to the *Potentiometer (HGx Models)* section.

Jumpers

AGx models come factory set with the Master/Slave Jumper in the master position and have no additional jumpers. **GGx, HGx, and JGx models** come factory set with Jumper W1 in the DA position. **GGx and HGx models** have additional jumpers factory set as follows: Jumper W2 is in the 0 to 10 VDC or 0 to 20 mA position, and Jumper W4 is in the 0 to 10 VDC position. (See Figure 8.)

Note: HGx models have an additional jumper, Jumper (W3), factory set in the fixed position. The **AGx models** do not have jumpers.

Potentiometers (HGx Models)

IMPORTANT: Adjust both zero and span potentiometers for full actuator travel and complete calibration.

The **HGx models** have zero and span potentiometers that do not require adjustment when Jumper W3 is factory set in the fixed position. When Jumper W3 is in the Adjustable (ADJ) position, without waiting for the actuator to drive to the final position, proceed as follows:

Adjust the zero and span potentiometers using either Terminal 3 and Terminal 5 or Terminal 3 and Terminal 4, a control signal, and a voltmeter.

Adjusting the Zero and Span

To adjust the zero and span potentiometers on the **HGx models**:

1. Verify that Jumper W2 is in the 0 to 10 VDC position, and provide 24 VAC or 24 VDC power to Terminal 1 (Common) and Terminal 2.
2. Connect the Common from the controller to Terminal 1, and either a voltage signal to Terminal 5 or a current signal to Terminal 4.
3. Connect Terminal 1 and Terminal 3 to a voltmeter to monitor the calibration output.
4. Use a 1/8 in. (3 mm) flat-blade screwdriver to turn the zero potentiometer fully CW and the span potentiometer fully CCW.
5. Apply the minimum (zero point) control signal required for positioning the actuator at the minimum position.
6. Monitor DC calibration output. To adjust the zero potentiometer, turn it CCW until the voltmeter displays 0 V or slightly less.
7. Adjust the control signal to the maximum voltage desired to cause full rotation.
8. Monitor the calibration output at Terminal 1 and Terminal 3. Adjust the span potentiometer CW to increase the calibration output to 10 V.
9. Verify that the actuator is properly calibrated by adjusting the control signal to the minimum and maximum levels.

Example for a zero of 3 VDC and a span of 5 VDC:

- Apply a 3 volt control signal to the actuator, and turn the zero potentiometer CCW until the calibration output at Terminal 3 is 0 V.
- Apply maximum voltage. (In this case, it is 8 VDC, which results in a span of 5 volts.)
- Monitor calibration output at Terminal 3, and adjust the span potentiometer CW to 10 V.

Auxiliary Switches (xGC Models)

The **M91xx-xGC models** have two built-in auxiliary switches that allow setting at any angle between 0 and 90° (factory set for 10 and 80°, nominal). Refer to the *Technical Specifications* section for auxiliary switch ratings.

The following procedures serve as examples to change the position of the auxiliary switch angles:

Switch S1

To change the angle of Switch S1 to 20°, refer to Figure 9 and proceed as follows:

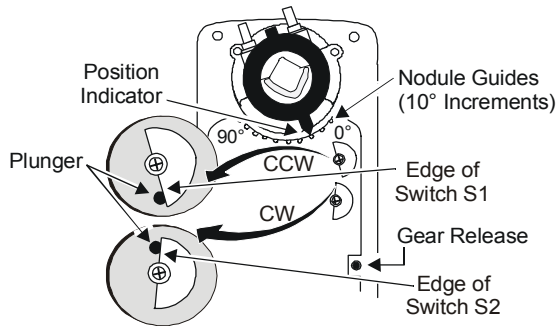

Figure 9: Switch Angle Settings

1. Depress the gear release, and using the 0 to 90° nodule guides, rotate the coupler until the position indicator is at 20°.
2. Loosen the screw on Switch S1 with a Phillips No.1 screwdriver.
3. Rotate Switch S1 CCW, and align the edge of the switch with the plunger until the plunger rises.

Note: The normally closed contact closes, and the normally open contact opens. (See Auxiliary Switches in Terminal Block 2 of Figure 5.)

4. Retighten the Phillips-head screw on Switch S1, while holding it in the designated position.

Switch S2

To change the angle of Switch S2 to 70°, refer to Figure 9 and proceed as follows:

1. Depress the gear release, and using the 0 to 90° nodule guides, rotate the coupler until the position indicator is at 70°.
2. Loosen the screw on Switch S2 with a Phillips No. 1 screwdriver.
3. Rotate Switch S2 CW, and align the edge of the switch with the plunger until the plunger rises.

Note: The normally closed contact opens, and the normally open contact closes. (See Auxiliary Switches in Terminal Block 2 of Figure 5.)

4. Retighten the Phillips-head screw on Switch S2, while holding it in the designated position.
5. Depress the gear release, and rotate the coupler until the position indicator is back to 0°.

Repairs and Replacement

Do not field repair the M9100 Series actuators. To order a replacement or an accessory, refer to the *Ordering Information* section in the *M9108, M9116, M9124, and M9132 Series Electric Non-spring Return Actuators Product Bulletin (LIT-2681058)*.

Technical Specifications

Product	M9108, M9116, M9124, and M9132 Series Electric Non-Spring Return Actuators		
Power Requirements	M9108-, M9116-AGx:	20 to 30 VAC at 50/60 Hz or 24 VDC ±10%; 6.5 VA supply, Class 2	
	All Other Models:	20 to 30 VAC at 50/60 Hz or 24 VDC ±10%; 7.5 VA supply, Class 2	
Input Signal	AGx:	24 VAC at 50/60 Hz or 24 VDC	
	GGx, HGx:	0 (2) to 10 VDC, 0 (4) to 20 VDC, or 0 (4) to 20 mA	
	JGx:	Potentiometer value is 100 ohms minimum to 10,000 ohms maximum	
Input Signal Adjustments	AGx:	Factory Setting:	Terminals 1 and 2, CW rotation Terminals 1 and 3, CCW rotation
	GGx, HGx (Voltage Input or Current Input):	Factory Setting:	0 to 10 VDC, 0 to 20 mA, CW rotation with signal increase
		Jumper Selectable:	0 (2) to 10 VDC, 0 (4) to 20 VDC, or 0 (4) to 20 mA
	HGx	Adjustable Zero:	0 to 6 VDC, 0 to 12 VDC, or 0 to 12 mA
		Adjustable Span:	2 to 10 VDC, 4 to 20 VDC, or 4 to 20 mA
	GGx, HGx, JGx:	Action is jumper selectable Direct (CW) or Reverse (CCW) with signal increase.	
Input Impedance	GGx, HGx:	Voltage Input:	205,000 ohms for 0 (2) to 10 V and 410,000 ohms for 0 (4) to 20 V
		Current Input:	500 ohms
	JGx:	Potentiometer Input:	1.8 megohms

Continued on next page. . .

Technical Specifications (Cont.)

Feedback Signal	AGD:	135 ohm feedback potentiometer
	AGE:	1,000 ohm feedback potentiometer
	GGx, HGx:	0 to 10 VDC or 2 to 10 VDC for 90° (10 VDC at 1 mA) Corresponds to input signal span selection.
	JGx:	0 to 10 VDC for 90° (10 VDC at 1 mA)
Auxiliary Switch Rating	xGC:	Two Single-Pole, Double-Throw (SPDT) switches rated at 24 VAC 1.5 A inductive, 3.0 A resistive; 35.0 VA maximum per switch, Class 2
Mechanical Output (Running Torque)	M9108 Series:	70 lb·in (8 N·m) for one unit; not intended for tandem use
	M9116 Series:	140 lb·in (16 N·m) for one unit
	M9116 (in tandem)	280 lb·in (32 N·m) for two units (GGx, HGx)
	M9124 Series:	210 lb·in (24 N·m) for one unit
	M9124 (in tandem)	420 lb·in (48 N·m) for two units (AGx, GGx, HGx)
	M9132 Series:	280 lb·in (32 N·m) for one unit, M9132 (in tandem) 560 lb·in (64 N·m) for two units (AGx, GGx)
Audible Noise Rating	45 dBA at 1 m	
Rotation Range	0 to 90° in 5-degree increments, mechanically limited to 93°	
Rotation Time	M9108:	30 seconds at 50% rated load, 25 to 50 seconds for 0 to 70 lb·in (0 to 8 N·m)
	M9116:	80 seconds at 50% rated load 70 to 115 seconds for 0 to 140 lb·in (0 to 16 N·m)
	M9124:	130 seconds at 50% rated load 115 to 175 seconds for 0 to 210 lb·in (0 to 24 N·m)
	M9132:	140 seconds at 50% rated load 115 to 205 seconds for 0 to 280 lb·in (0 to 32 N·m)
	Electrical Connection	M9124-, M9132-AGx:
	All Other Models:	Screw terminals for 22 to 14 AWG; maximum of two 18, 20, or 22 AWG per terminal
Mechanical Connection	3/8 to 3/4 in. (10 to 20 mm) diameter round shaft or a 3/8 to 5/8 in. (10 to 16 mm) square shaft	
Enclosure	NEMA 2, IP42	
Ambient Conditions	Operating:	-4 to 122°F (-20 to 50°C); 0 to 95% RH, noncondensing
	Storage:	-40 to 186°F (-40 to 86°C); 0 to 95% RH, noncondensing
Dimensions (H x W x D)	7.09 x 3.94 x 2.54 in. (180 x 100 x 64.5 mm)	
Shipping Weight	2.9 lb (1.3 kg)	
Agency Compliance	UL Listed, File E27734, CCN XAPX CSA Certified, File LR85083, Class 3221 02 CE Mark, EMC Directive 89/336/EEC	

The performance specifications are nominal and conform to acceptable industry standards. For application at conditions beyond these specifications, consult the local Johnson Controls office. Johnson Controls, Inc. shall not be liable for damages resulting from misapplication or misuse of its products.



Controls Group
507 E. Michigan Street
P.O. Box 423
Milwaukee, WI 53201

Printed in U.S.A.
www.johnsoncontrols.com